



City of Odessa

228 S Second Street • PO Box 128 • Odessa, MO 64076
Phone: 816-230-5577 • info@cityofodessamo.com
www.cityofodessamo.com

INVITATION TO BID / REQUEST FOR PROPOSALS

This Document Contains the Following:

PART I	Invitation to Bid
PART II:	Instruction to Bidders
PART III:	General Instructions
PART IV:	Acknowledgement of General Terms & Conditions
PART V:	Supplemental Bond Terms Specific to Project
PART VI:	Technical Specifications / Bidder's Proposal
PART VII:	Bid Page

**Part I
Request for Bids
Bid No. 03-24**

The City of Odessa, Missouri will accept bids from qualified contractors interested in providing the following:

Light Poles and Bollards (Furnish Only)

**BIDS MUST BE RECEIVED AND WILL BE OPENED ON:
July 16, 2024 – 10:00 am**

Please mark your bid "Sealed Bid 03-24" and return it to:

Please return your bid to:
City of Odessa
228 S Second Street
PO Box 128
Odessa, MO 64076
Attn: Shawna Davis

For more information during business hours, contact
Scott Vilas: 832.535.7204 or at scott@navigatebuildingsolutions.com

Part II: Instruction to Bidders

1. Bidders shall give unit prices, extend totals and sign the bid.
2. Bidders shall begin generating approval shop drawings immediately following contract award.
3. Late proposals will not be considered, opened or evaluated regardless of the reason.
4. Bidders must submit documentation of compliance with E-Verify requirements.
5. Bidders must submit references from previous clients of related work with the Contractor within the past five (5) years.

Proposals should be submitted no later than July 16, 2024 at 10:00 am to the City of Odessa, Missouri. Mailed bids should be addressed to the City of Odessa delivered to: City Hall – Attn: Shawna Davis, 228 S. Second Street, PO Box 128, Odessa, MO 64076, clearly marked “Bid No. 03-24.” For more information, contact Scott Vilas, Navigate Building Solutions – 832-535-7204 or by email at scott@navigatebuildingsolutions.com.

Part III: General Instructions

1. The City of Odessa reserves the right to waive defects and informalities in proposals, to reject any or all proposals, or to accept any proposals as may be deemed in the best interest of the City, in its sole discretion.
2. The City of Odessa reserves the right to accept single line items of the bid and to reject others.
3. Any submission may be withdrawn at any time prior to the time specified herein for the opening of submissions, but no submission may be withdrawn for a period of ninety (90) days thereafter. The City Administrator, Shawna Davis will notify the successful bidder of acceptance of the bid and discuss the specific terms of the contract with the successful bidder. Once the specific terms of the contract have been finalized, the City Administrator will bring the contract to the Board of Alderman for final approval.
4. The City of Odessa will not be liable for any costs that a Contractor may incur in the preparation of or presentation of the proposal.
5. The City of Odessa shall not be obligated to return the Contractor’s proposal once submitted, whether the proposal is withdrawn or not.
6. The selected bidder shall provide all equipment, products, materials, supplies and services necessary for the proper execution and implementation of the agreement.

- 7.** The costs agreed to are to be firm and final. Underestimation of the complexity of the task will not warrant an increase in the price. The Bidder shall make any additional inquiries necessary to properly evaluate its compensation and prepare its bid proposal accordingly.
- 8.** Any explanation desired by a bidder regarding the meaning or interpretation of the RFP must be requested in writing with sufficient time allowed for a reply to reach bidders before the deadline for submission.
- 9.** The City of Odessa reserves the right to waive any informality, reject any or all proposals and/or cancel this RFP, all without any obligation to the City. The City shall select the vendor which, based upon its response to this RFP, it regards to be the best qualified, responsible, and capable of performing the desired work in a timely fashion at the lowest price.
- 10.** No bidder shall be permitted to use to his or her advantage any error or omission in this Invitation to Bid or related specifications.



STATEMENT OF QUALIFICATIONS PROPOSAL SIGNATURE FORM

By signing below, I am certifying that I am submitting this proposal as an authorized representative of the below-named firm, have thoroughly reviewed and understand the terms and conditions of the RFP, and am submitting the proposal accordingly.

Dated this _____ day of _____, 2024.

(Authorized Representative Signature)

(Authorized Representative Name/Title)

(Company Name)

(Address)

(City, State, Zip)

(Phone Number/Fax Number)

(Email Address)

THIS FORM MUST BE SUBMITTED WITH THE QUALIFICATIONS
Part IV: Acknowledgement of General Terms and Conditions Pertaining to All
City Contracts

1. Definitions.

- (a) "Owner" or "City" shall refer to the City of Odessa, Missouri.
- (b) "Vendor", "Seller", "Firm", "Bidder", and "Contractor" are terms which refer to the corporation, company, partnership, firm or individual named and designated in this contractual agreement and who has voluntarily entered into this contract and its, his or their duly authorized agents or other legal representatives.
- (c) "Sub-contractor" is a person, firm or corporation supplying labor or material for, and under separate contract or agreement with the Contractor.

2. Contract Documents. This Request for Quotation, including without limitation any completed forms as required by the applicant shall be made a part of any additional Agreement/Contract executed between Owner and the winning bidder regarding the subject matter herein.

3. Contract Terms. The performance of the contract shall be governed solely by the terms and conditions of the contract and any specifications or bid documents, notwithstanding any language contained in any invoice, shipping order, bill of lading or other document furnished to the Seller/Contractor at any time and the acceptance by the City of any terms or conditions contained in such document which is inconsistent with the terms and conditions set forth in the contract. Any different or additional terms other than those herein contained are hereby objected to. Submission of a bid constitutes an assignment by you of any and all anti-trust claims that you may have under the Federal and/or State laws.

4. Patents. Bidder warrants that the articles described herein and the sale or use of them will not infringe upon any U.S. or foreign patent and covenants that Contractor will at its own expense, defend every suit which may be brought against the City, or those selling or using City's product for any alleged infringement of any patent by reason of the sale or use of such articles and agrees that it will pay all costs, damages and profits recoverable by any such suit.

5. Interpretation of Contract. This contract shall be construed according to the laws of the State of Missouri.

6. Fund Allocation. Continuance of any resulting Agreement, Contract, or issuance of Purchase Orders is contingent upon the allocation of City funds by the Board of Alderman.

7. Tax Exempt. The City is exempt from payment of the Missouri Sales Tax in accordance with Section 39(10), Article 3 of the Missouri constitution and is exempt from payment of Federal Excise Taxes in accordance with Title 26, United States Code annotated.

8. Provisions Required by Law Deemed Inserted. Each and every provision or law and clause required by law to be inserted in a contract will be deemed to be inserted and the contract will be read and enforced as though it were included herein, and if through mistake or otherwise any such provision is not inserted, or is not correctly inserted, then upon the application of either party the contract will forthwith be amended to make such insertion or correction.

- 9. Termination of Contract.** In the event this bid establishes a year supply or service contract, such contract may be terminated by either party with or without cause upon thirty (30) days prior notice in writing to the other party. In the event of such termination, the Bidder shall be liable for any excess costs incurred by the City. If the Contract is so terminated, the City may purchase such supplies or services similar to those so terminated, and the Bidder will be liable for excess costs occasioned thereby.
- 10. Acts of God.** Neither party shall be liable for delays, or defaults in the performance of this contract due to acts of God or the public enemy, riots, strikes, fires, explosions, accidents, Government action of any kind or any other causes of a similar character beyond its control and without its fault of negligence.
- 11. Bankruptcy or Insolvency.** In the event of any proceedings by or against either party, voluntary or involuntary, in bankruptcy or insolvency, or for the appointment of a receiver or trustee or an assignee for the benefit of creditors, of the property of Owner, or in the event of breach of any of the terms hereof including the warranties of the Bidder, City may cancel this contract or affirm the contract and hold Contractor responsible for damages.
- 12. Compliance with Applicable Laws.** Bidder warrants it has complied with all applicable laws, rules and ordinances of the United States, or any State, Municipality or any other Governmental authority or agency in the manufacture or sale of the items or services covered by this contract, including, but not limited to: all provisions of the Fair Labor Standards Act of 1938, as amended.
- 13. Execution of this Agreement.** Unless otherwise specified, the contract shall include, and incorporate by reference, a copy of the signed bid and all attachments thereto. These documents become the agreement and contract between the parties hereto. Upon Board approval, both parties accept and agree to the terms and conditions of the bid documents, and the parties agree to be bound thereto. The compensation to be paid to the winning bidder is as set forth in the agreed upon bid. Items not awarded, if any, will be deleted.
- 14. Contractor's Invoices.** The City shall not make any advance deposits. Payment for all equipment, supplies and/or services required herein shall be made in arrears. Discounts offered for prompt payment will be considered in bid evaluation.

All invoices shall contain the following information: Contractor's name, address, and telephone number, contract number (if any), purchase order number (if any), item number, contract description of supplies or services, sizes, quantities, unit prices and extended totals. Delay in receiving invoices, also errors and omissions on statement or invoices, will be considered just cause for withholding settlement without losing discount privileges. Invoices for payment should be sent by U.S. Mail (or hand delivered) and addressed to: City of Odessa, PO Box 128, Odessa, MO 64076. Inquiries regarding invoices or payment should be made to Accounts Payable at (816) 230-5577 ext. 5. All items for the Work will be paid in a single lump sum payment to the successful bidder within thirty (30) days after the latest of the following occurrence's:

- The date of delivery of the materials or construction services purchased;
- The date upon which the written invoice for such materials and services is delivered by hand or by U.S. Mail, to the City Clerk at 228 S. 2nd Street (PO Box 128), Odessa, Missouri, 64076; or

Bidders are informed that the successful bidder shall comply with the Missouri Public Prompt Payment Act (Sections 34.057 and 34.058, RSMo) regarding payments to subcontractors and material suppliers in relation to the contract awarded as a result of this Invitation for Bids.

The City expressly reserves its rights to withhold, in good faith, payment or final payment in accordance with Section 34.057.5, RSMo, and in accord with the contract awarded as a result of this Invitation for Bids. Final payments will be made in accordance with Section 34.057, RSMo.

- 15. Time of Delivery.** The City requires that all materials ordered and services rendered be delivered when specified. If deliveries are not made at the time agreed upon, the City reserves the right to cancel or to purchase elsewhere and to hold Contractor accountable for any damages as a result thereof, including reasonable attorney fees.
- 16. Quantities.** The City assumes no obligation for articles or materials shipped in excess of the quantity ordered hereunder. Any unauthorized quantity is subject to City's rejection and returned at Contractor's expense.
- 17. Responsibility for Supplies.** The Contractor shall be responsible for supplies until they are delivered and accepted at the designated delivery point; and the Contractor shall bear all risks for rejected supplies after notice of rejection.
- 18. Coordination of the Work and Surplus Materials and Rubbish.** The Contractor shall be responsible for the proper execution of all work and for the coordination of the operations of all trades, subcontractors, and suppliers engaged under this contract. Contractor shall be prepared to provide each of its sub-contractors the location, measurements and information they may require for the performance of their work. The job site shall be kept clean and free of surplus materials, rubbish and debris at all times.
- 19. Inspection and Acceptance.** No material or service received by the City pursuant to this Contract shall be deemed accepted until the City has had a reasonable opportunity for inspection. All material or service which is discovered to be defective or which does not conform to any warranty of the Seller herein upon initial inspection, or any later time if the defects were not reasonably ascertainable upon the initial inspection, may be returned (if materials) for full credit or replacement and shall be immediately rectified at Contractor's expense (if service).
- 20. General Guaranty and Warranty.** The Contractor warrants that all materials, fixtures and equipment furnished by the Contractor and his subcontractors shall be new, of good quality and of good title, and that the work will be done in a neat and workmanlike manner and to the complete specifications set forth herein. The Contractor also guarantees the workmanship and materials for a period of two years from the date of final acceptance of all the work required by the Contract. Furthermore, Contractor shall furnish the Owner with all manufacturers' and suppliers' written guarantees and warranties covering materials and equipment furnished under the contract.
- 21. Regulations Pursuant to "Anti-Kickback Act".** The Contractor shall comply with the applicable regulations of the Secretary of Labor, United States Department of Labor, made pursuant to the "Anti-Kickback Act" of June 13, 1934 (48 Stat. 948; 62 Stat. 862; title 18 U.S.C., Section 874; and Title 40 U.S.C., Section 276©, and any amendments or modifications thereto, shall cause appropriate provisions to be inserted in sub-contracts to insure compliance therewith by all sub-contractors subject thereto, and shall be

responsible for the submission of statements required of sub-contractor's subject there under, except as said Secretary of Labor may specifically provide for reasonable limitations, variations, tolerances and exemption from the requirements thereof.

22. Changes in Project. The City may at any time, by written order, without notice to any surety, make changes or additions, within the general scope of this contract in or to drawings, designs, specifications, instructions for work, method of shipment or packing or place of delivery. If any such changes cause an increase or decrease in the cost or in the time required for performance of this contract or purchase order, the Contractor shall notify the City in writing immediately and an appropriate equitable adjustment will be made in the price or time of performance, or both, by written modification of the Contract. Any claim by the Contractor for such adjustment must be asserted within 30 days, or such other period as may be agreed upon, in writing by the parties after the Contractor's receipt of notice of the change.

Contractor shall not make changes in the work, by adding work or by changing materials, fixtures or services from those specified without the prior written consent of the City. Any authorized changes will not relieve or release the Contractor from any of these obligations under the contract. All work shall be executed under the terms of this original contract, unless it is expressly provided otherwise. Except for the purpose of affording protection against any emergency endangering life and/or property, the Contractor shall not make any changes in the contract. Each change order shall include in its final form, a detailed description of the change in the work, the Contractor's proposal for the change in price and/or time, and the statement that all work involved in the change shall be performed in accordance with Contract requirements except as modified by the change.

Nothing herein contained shall excuse the Contractor from proceeding with the Contract as changed.

23. Assignments. Neither Owner nor Contractor shall, without the prior written consent of the other, assign in whole or in part, his interest under any of the Contract documents and specifically the Contractor shall not assign any monies due or to become due without the prior written consent of the Owner.

24. Work Hours and Safety Standard Act. All bidders on projects that involve the employment of mechanics or laborers shall comply with Sections 103 and 107 of the Contract Work Hours and Safety Standards Act (40 U.S.C. 327-330) as supplemented by the Department of Labor Regulations (29CFR, part 5). Under Section 103 of the Act, each Contractor shall be required to compute wages of every mechanic and laborer on the basis of a standard work day of 8 hours and a standard work week of 40 hours. Work in excess of the standard work day or work week is permissible provided that the work is compensated at a rate of not less than 1 ½ times the basic rate of pay for all hours worked in excess of 8 hours in any calendar day or 40 hours in the work week.

25. Labor-Related Regulations. The bidder's attention is specifically directed to the special rules, regulations and stipulations pertaining to labor listed below which may be a part of the bid as stipulated in the supplemental contractual requirements. (a) Wage Rate Stipulation – State of Missouri. ; (b) Wage Rate Determination – Federal. The bid, agreement and bonds shall be conditioned upon compliance with all labor related obligations as determined by the Missouri Division of Labor and Contractor agrees to be educated and abide by the requirements of same.

26. Sub-Contracts. The Contractor shall not execute an agreement with any sub-contractor to perform any work until it has written to the City to determine the disapproval of the use of such sub-contractor. The Contractor shall be fully responsible to the City for the acts and omissions of its sub-contractors, and of persons either directly or indirectly employed by them, as it is for the acts and omissions of persons directly employed by him. The Contractor shall cause appropriate provisions to be inserted in all sub-contracts relative to the work to require compliance by each sub-contractor with the applicable provisions of this contract. Nothing contained herein shall create any contractual relationship between any sub-contractor and the Owner.

27. Accident Prevention and Training. The Contractor and all subcontractors to the contract must require all on-site employees to complete the ten-hour construction safety training program required under Section 292.675 RSMo, if they have not previously completed the program and have documentation of having done so available. The Contractor will forfeit a penalty to the contracting public body of \$2,500 plus an additional \$100 for each employee employed by the Contractor or sub-contractor, for each calendar day, or portion thereof, such employee is employed without the required training. The Contractor will provide an Affidavit of Compliance with RSMo 292.675 stating that Contractor and all subcontractors doing work in connection with the contracted services have provided its on-site employees with a ten (10) hour course in construction safety and health approved by OSHA.

The Contractor shall exercise proper precaution at all times for the protection of persons and property and shall be responsible for all damages to persons or property, either on or off the site, which occur as a result of its prosecution of the work. The safety provisions of applicable laws and building and construction codes shall be observed and the Contractor shall take or cause to be taken such additional safety and health measures as the City may determine to be reasonably necessary. All materials, parts, supplies, and services rendered under the technical specifications must comply with the standards of the Williams Steiger Operational and Safety Health Act. In consideration of the price paid herein, Contractor agrees to indemnify the City for any penalties imposed by the Act arising out of misfeasance or malfunction of items or services purchased.

The Contractor shall maintain an accurate record of all causes of death, occupational disease and injury requiring medical attention or causing loss of time from work, arising out of and in the course of employment on work under the contract. The Contractor shall promptly furnish the City with reports concerning these matters.

28. Non-Discrimination in Employment. In connection with the furnishing of supplies or performance under this contract, the Contractor agrees to comply with the Fair Labor Standards Act, Fair Employment Practices, Equal Opportunity Employment Act, and all other applicable Federal and State Laws, and further agrees to insert the foregoing provision in all sub-contracts awarded hereunder.

29. Minority & Women Business Enterprise Participation. It is the practice of the City of Odessa to ensure full and equitable economic opportunities to persons and businesses that compete for business with the City, including Minority and Women Business Enterprises (M/WBEs).

The City of Odessa encourages M/WBE participation in contracts for goods and services by firms that are certified. This may either be by the primary firm being a certified M/WBE or by the

utilization of qualified subcontractors, suppliers, joint ventures or other arrangements that afford meaningful opportunities for M/WBE participation. Work performed by M/WBEs must provide a commercially useful function related to the delivery of the service/product required herein. Second tier participation where suppliers generally provide supplies to a corporation but that are not directly related to this contract does not qualify as meaningful participation.

M/WBE means a business that is a sole proprietorship, partnership, joint venture or corporation in which at least fifty-one percent (51%) of the ownership interest is held by minorities or women and the management and daily business operations of which are controlled by one or more minorities or women who own it. Minority is defined as belonging to one of the following racial minority groups: African Americans, Native Americans, Hispanic Americans, Asian Americans, American Indians, Eskimos, Aleuts and other groups that may be recognized by the Office of Advocacy, United States Small Business Administration.

30. Building Regulation, Permits and Law. Contractor agrees to satisfy all current and applicable local codes and ordinances.

31. Insurance. During the course of performing its services, the Contractor will maintain the following minimum insurance coverage:

<u>Type of Coverage</u>	<u>Limits of Liability</u>
Workers' Compensation	Statutory
Employers' Liability	\$500,000
Comprehensive General Liability	\$1,000,000 per occurrence, \$2,000,000 aggregate
Automobile Liability	\$1,000,000 per occurrence, \$2,000,000 aggregate
Umbrella	\$2,000,000

Owner will be listed as an additional insured in respect to general liability, automobile liability, and umbrella/excess insurance. However, the addition of Owner as an additional insured shall not in any way nullify coverage for claims or actions Owner may have against the Contractor. The Contractor will provide to the City certificates evidencing the required coverage prior to commencing services.

32. Timing. Upon receipt of Contract documents fully executed by Owner, the Contractor shall immediately provide the City with all required copies of insurance policies as set forth in the preceding paragraph and proceed with work on the date specified therein.

33. United States and Local Products Preference. Bidders are informed that the Missouri Domestic Producers Procurement Act (Sections 34.350 to 34.350, RSMo) requires manufactured goods or commodities used and supplied in the performance of a contract for construction, alteration, repair, or maintenance of any public works, which contract is valued at \$25,000 or more, to be manufactured or produced in the United States.

Bidders are further informed that the City of Odessa has adopted a resolution establishing the City's preference for local businesses, a copy of which policy is available upon request to the City Clerk. Consequently, the award of contracts for materials and supplies and for labor will be made in accordance with that policy. Furthermore, successful bidders will be required to abide by the City's policy in completing the Work.



Part V: Supplemental Bond Terms Specific to the Project

1. Bid Bonds.

Bid Bond Not Required _____

Bid Bond Required _____ X _____

Note the following if bid bond required:

Bid Deposit. The Bidder will furnish a bid deposit in the form of a bond, certified check, cash or bank draft in the amount of 5% of the total bid price payable to the City of Odessa for the measure of liquidated damages which the City will sustain and the proceeds thereof will become the property of the City if for any reason the bidder: a) withdraws its bid after the opening of the bids and prior to the time a formal written agreement evidencing the contract has been signed and delivered to the City, whether or not the bidder at the time of such withdrawal has been designated as successful bidder; or b) upon written notification of the award of contract to bidder he/she/it fails to properly sign and deliver to the City within fourteen (14) days labor and materials and performance bond (if required) as well as certificates of insurance.

The bidder further agrees that the City will have the right to retain the bid deposit for a period of sixty (60) days from the date of the opening of the bids. At the expiration of said time, or earlier at the option of the City, said bid deposit will be returned to the bidder unless said bid deposit has become the property of the City as liquidated damages on the reasons stipulated above.

2. Payment and Performance Bonds:

Payment and Performance Bond Not Required _____ X _____

Payment and Performance Bond Required _____

Note the following if performance bond required:

Within seven (7) days of the Notice to Proceed, Contractor shall furnish to the City a contract performance bond and a labor and material payment bond. The bonds shall be executed with the proper sureties, through a company licensed to do business in the State of Missouri, and named on the current list of "surety Companies Acceptable on Federal Bonds" as published in

the Federal Register by the Audit Staff of the Bureau of Accounts and Treasury Department. The date of the bonds shall be prior to the date the work is commenced by the Contractor. The performance bond shall be in the amount of the full contract price, guaranteeing the payment of all bills and obligations arising from the performance of the contract, and otherwise conditioned as required by law. The bonds shall be automatically increased in the amount and extended in time without formal and separate amendments to cover full and faithful performance of the contract in the event of change orders, regardless of the amount of time or money involved. It shall be the Contractor's responsibility to notify the surety of any changes affecting the general scope of the work or change in the contract price. At any time during the continuance of the contract that the surety on any bond becomes unacceptable to the City, the City shall have the right to require additional and sufficient sureties which Contractor shall furnish to the satisfaction of the City within ten (10) days after notice to do so.

By: _____ (signature)

Printed Name and Title: _____

For and on behalf of: _____ (Company)

FEDERAL WORK AUTHORIZATION PROGRAM (“E-VERIFY”) ADDENDUM

For Contracts with the City of Odessa, Missouri:

Pursuant to Missouri Revised Statute 285.530, all business entities awarded any contract in excess of five thousand dollars (\$5,000) with a Missouri political subdivision must, as a condition to the award of any such contract, be enrolled and participate in a federal work authorization program with respect to the employees working in connection with the contracted services being provided, or to be provided, to the City (to the extent allowed by E-Verify). In addition, the business entity must affirm the same through sworn affidavit and provision of documentation. In addition, the business entity must sign an affidavit that it does not knowingly employ any person who is an unauthorized alien in connection with the services being provided, or to be provided, to the City.

Accordingly, your company:

- (a) Agrees to have an authorized person execute the attached “Federal Work Authorization Program Affidavit” and deliver the same to the City prior to or contemporaneously with the execution of its contract;
- (b) Affirms it is enrolled in the “E-Verify” work authorization program in the United States, and is participating in E-Verify with respect to your employees working in connection with the services being provided (to the extent allowed by E-Verify), or to be provided;
- (c) Affirms that it is not knowingly employing any person who is an unauthorized alien in connection with the services being provided, or to be provided, by your company to the district.
- (d) Affirms you will notify the City if you cease participation in E-Verify, or if there is any action, claim or complaint made against you alleging any violation of Missouri Revised Statute 285.530, or any regulations issued thereto;
- (e) Agrees to provide documentation of your participation in E-Verify to the City prior to or contemporaneously with the execution of its contract with the City (or at any time thereafter upon request), by providing an E-Verify screen print out (or equivalent documentation) confirming your participation in E-Verify;
- (f) Agrees to comply with any state or federal regulations or rules that may be issued subsequent to this addendum that relate to Missouri Revised Statute 285.530; and
- (g) Agrees that any failure by your company to abide by the requirements a) through f) above will be considered a material breach of your contract with the City of Odessa.

By: _____ (signature)

Printed Name and Title: _____

For and on behalf of: _____ (Company)

THIS FORM MUST BE SUBMITTED WITH THE QUALIFICATIONS

FEDERAL WORK AUTHORIZATION PROGRAM AFFIDAVIT

I, _____, being of legal age and having been duly sworn upon my oath, state the following facts are true:

1. I am more than twenty-one years of age; and have first-hand knowledge of the matters set forth herein.

2. I am employed by _____ (“Company”) and have authority to issue this affidavit on its behalf.

3. Company is enrolled in and participating in the United States E-Verify federal work authorization program with respect to Company’s employees working in connection with the services Company is providing to, or will provide to the City of Odessa, to the extent allowed by E-Verify.

4. Company does not knowingly employ any person who is an unauthorized alien in connection with the services Company is providing to, or will provide to, the City.

FURTHER AFFIANT SAYETH NOT.

By: _____ (Signature)

Print Name/Title: _____

On Behalf of: _____ (Company)

STATE OF _____)
) ss.

COUNTY OF _____)

Submitted and sworn to before me this ____ day of _____, 2020.

Notary Public

Print Notary Name

My commission expires:

THIS FORM MUST BE SUBMITTED WITH THE QUALIFICATIONS



City of Odessa

228 S Second Street • PO Box 128 • Odessa, MO 64076
Phone: 816-230-5577 • info@cityofodessamo.com
www.cityofodessamo.com

Part VI

Bid No. 03-24
Light Poles and Bollards (Furnish Only)
Odessa, MO 64076

Scope of Work

- Selected Contractor shall be licensed to do business within the City of Odessa, MO
- The City reserves the right to refuse all bids and/or not award a bid on any or all parts of the project

Specifications for the Project

1. The City of Odessa, Missouri is soliciting bids for the Downtown Street Improvements Light Pole and Bollard (Furnish Only) Package located at 228 S 2nd St, Odessa, MO 64076. The project scope of work must include the following:
 - a. Furnish of Light Poles, Fixtures and Bollards
 - b. For Approval Shop Drawings
 - c. All required mounting hardware and anchor bolts
 - d. Insurance up to the point of delivery of fixtures and bollards
 - e. Payment & Performance Bond – If required
 - f. Warranty including manufacturer's full warranty
2. Upon fixtures being ready to ship, Contractor shall coordinate with City to set up time to deliver and off load of shipment.
3. All material deliveries shall be sent to 900 W Dryden St, Odessa, MO 64076
4. The Contractor shall include all costs associated with shipping of materials.
5. The Owner shall be responsible for offloading of material upon delivery.
6. The Owner shall be allotted up to 2 weeks for review of shop drawings.

Light Poles

1. Contractor shall provide light poles as detailed in drawings generated by Holophane dated 05/30/2024.
2. Light fixture quantities shall align with the Structure Schedule on sheet TSG015484 Rev C.
3. Contractor shall include all mounting components and hardware including but not limited to anchor bolts, nuts, plates, washers, bolt template, fixtures, bulbs, etc.

Bollards

1. Contractor shall provide (64) sixty-four cast aluminum illuminated LED bollards meeting the following performance criteria:
 - a. Material: Cast Aluminum
 - b. Bollard Color: Black
 - c. LED Fixture Color: 4000K
 - d. GFCI Power Outlet with wet location cover: 120V
 - e. Light Fixture Throw: Front Throw/Type 3
 - f. Bollard Base Diameter: Minimum 9", Maximum 13"
 - g. Bollard Height: Minimum 42"
 - h. Glass Lense: Clear
 - i. Basis of design: Holophane CLBOLED
2. Contractor shall include all mounting components and hardware including but not limited to anchor bolts, nuts, plates, washers, bolt template, fixtures, bulbs, etc.

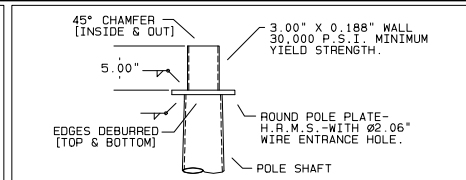
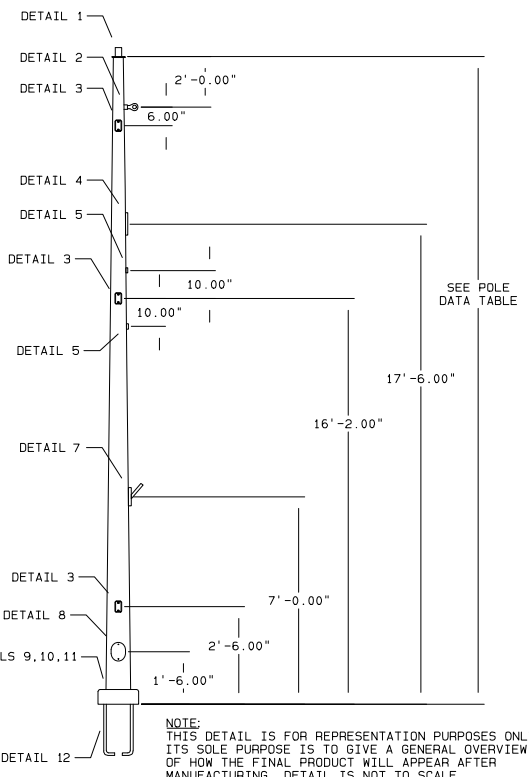

DETAIL 1 POLE TOP TENON

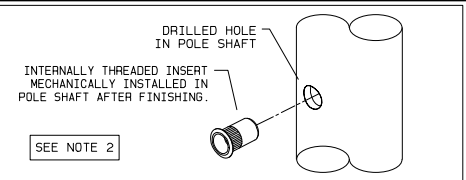

DETAIL 6 TYPICAL RIVNUT DETAIL

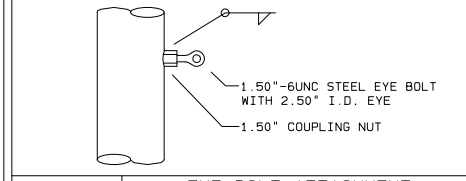

DETAIL 2 EYE BOLT ATTACHMENT

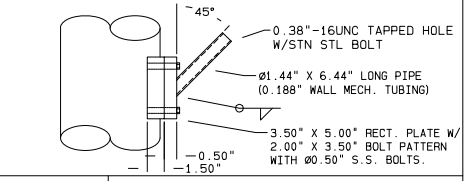

DETAIL 7 FLAG HOLDER

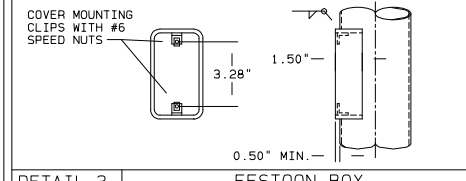

DETAIL 3 FESTOON BOX

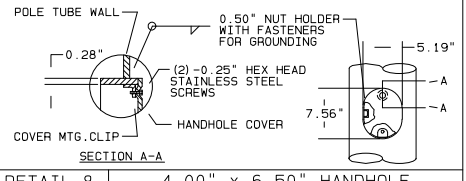

DETAIL 8 4.00" x 6.50" HANDHOLE

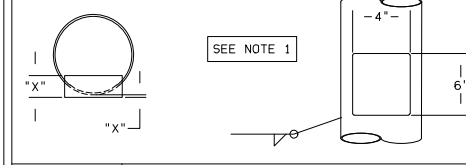

DETAIL 4 CAMERA ARM MOUNTING PLATE

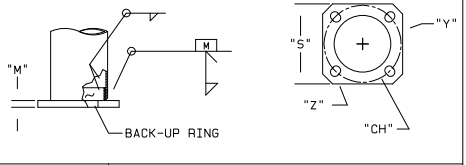

DETAIL 9 POLE BASE

RFD344285 & RFD344286

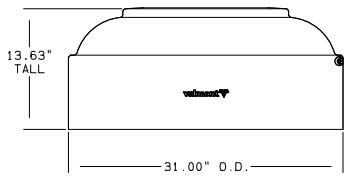

DETAIL 11 RL31AC DECORATIVE BASE

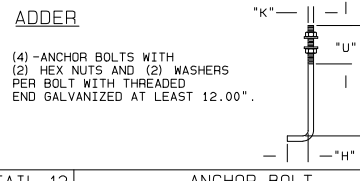

DETAIL 12 ANCHOR BOLT

MATERIAL DATA

COMPONENT	ASTM DESIGNATION	MIN YIELD (KSI)
TAPERED SHAFTS	A595 GR. A OR A572	55
BASE PLATE	A36	36
TOP PLATE	A36	36
ANCHOR BOLT (ADDER)	F1554 GR105	105
HARDWARE - COATING	HOTDIP ZINC	--

FINISH DATA

SYSTEM: FINISH PAINTED (FP)
 BASE COAT: NONE
 PRIME COAT: NONE
 FINISH COAT: TGIC OR URETHANE POLYESTER POWDER
 COLOR: BLACK
 SPEC: F-2644

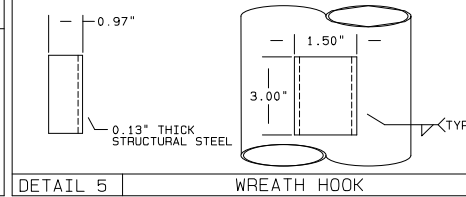

DETAIL 5 WREATH HOOK

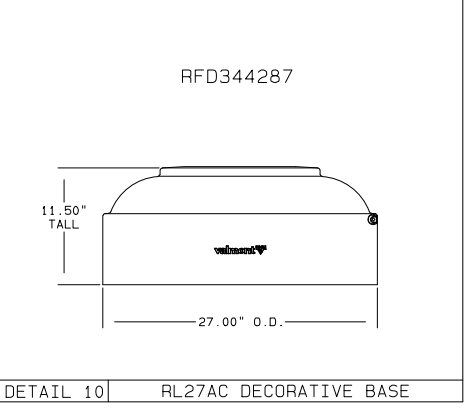

DETAIL 10 RL27AC DECORATIVE BASE

CUSTOMER NOTES:

- CUSTOMER SHALL VERIFY DRAWING DETAILS AND PROVIDE PRIOR TO PRODUCTION.
- ANCHORAGE DETAIL PROVIDED FOR VISUAL ONLY - DO NOT USE TO SET ANCHOR BOLTS.
- SIGNED APPROVAL TO ACCOMPANY PO.

Catalog #'s:
 *Complete CAT NOS on Sheets 2 & 3

Customer Signature & Date:

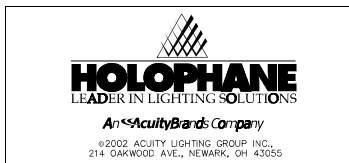

STRUCTURE SCHEDULE

ITEM	QTY.	DESIGN DESCRIPTION	TUBE DATA			BASE PLATE DATA				ANCHOR BOLTS (ADDER)					
			BASE DIA. (IN)	TOP DIA. (IN)	LENGTH (FT)	GAUGE OR THK. (IN)	SQUARE "S" (IN)	CENTER HOLE "CH" (IN)	BOLT CIRCLE "Y" (IN)	THK. "M" (IN)	HOLE "Z" (IN)	DIA. "K" (IN)	LENGTH "J" (IN)	HOOK "H" (IN)	THREAD LENGTH "U" (IN)
RFD344285	2	DS210-F50M260-P9-FP-EYEBOLT-FST-CAM-NUTSERTS- WREATH-SFBC-LAB-BAA	15.50	11.86	26.00	0.313	21.00	8.50	20.50	2.00	2.50	2.25	89.00	7.00	12.00
RFD344286	2	DS210-F50M260-P9-FP-EYEBOLT-FST-CAM-NUTSERTS- WREATH-SFBC-LAB-BAA	15.50	11.86	26.00	0.313	21.00	8.50	20.50	2.00	2.50	2.25	89.00	7.00	12.00
RFD344287	16	DS210-E00J260-P9-FP-EYEBOLT-FST-CAM-NUTSERTS- WREATH-SFBC-LAB-BAA	11.00	7.36	26.00	3	17.00	10.50	16.00	2.00	2.00	1.75	84.00	6.00	8.00

C MAB 05/30/24	MAB 05/30/24	REMOVED STRAP FROM BHC ARM (SEE SHTS 3,4,5)	SOLD TO: ODESSA STREETSCAPE 2024	JOB ODESSA STREETSCAPE 2024	ORDER NUMBER: MO596482P2
B MAB 05/06/24	MAB 05/06/24	ADDED SHEETS 3, 4, 5 FOR COMPOSITES.	SHIP TO: ODESSA, MO	ODESSA, MO	PAGE NUMBER: 1 OF 5
A SSK 04/24/24	SSK 04/24/24	CORRECTED DETAIL TAGS 7, 8, 11, 12	P.O. # 23-12261-17 (DR-28086, RFD344285/344286/344287)	TITLE SPAN WIRE STRUCTURES	DRAWING NUMBER TSG015484
TSB 04/12/24	KB8 04/15/24		AGENT: KEVIN LYNCH		REV C

THE LIGHTING STRUCTURES SHOWN ON THIS DRAWING HAVE BEEN DESIGNED IN ACCORDANCE WITH THE LOADINGS AND THE ALLOWABLE STRESS REQUIREMENTS OF THE 2013 AASHTO "STANDARD SPECIFICATIONS FOR STRUCTURAL SUPPORTS FOR HIGHWAY SIGNS, LUMINAIRES AND TRAFFIC SIGNALS", SIXTH EDITION, LTS-6. THE WIND LOADS WERE CALCULATED FROM A BASIC WIND VELOCITY OF 90 MPH WITH A RECURRENCE INTERVAL OF 50 YEARS.

- PER THE CODE COMMON LIGHTING STRUCTURES ARE NOT REQUIRED TO BE ANALYZED FOR FATIGUE LOADS AS THEY HAVE NOT NORMALLY EXHIBITED FATIGUE PROBLEMS.

AASHTO 2013 SPECIFICATIONS

ALTHOUGH RARE, VIBRATIONS SEVERE ENOUGH TO CAUSE DAMAGE CAN OCCASIONALLY OCCUR IN STRUCTURES OF ALL TYPES. BECAUSE THEY ARE INFLUENCED BY MANY INTERACTING VARIABLES, VIBRATIONS ARE GENERALLY UNPREDICTABLE. THE USER'S MAINTENANCE PROGRAM SHOULD INCLUDE OBSERVATION FOR EXCESSIVE VIBRATION AND EXAMINATION FOR ANY STRUCTURAL DAMAGE OR BOLT LOOSENING. THE VALMONT WARRANTY SPECIFICALLY EXCLUDES FATIGUE FAILURE OR SIMILAR PHENOMENA RESULTING FROM INDUCED VIBRATION, HARMONIC OSCILLATION OR RESONANCE ASSOCIATED WITH MOVEMENT OF AIR CURRENTS AROUND THE PRODUCT.

VIBRATION DISCLAIMER

ALL ANGLES MEASURED CLOCKWISE FROM HAND-HOLE AS VIEWED FROM SMALL END OF POLE

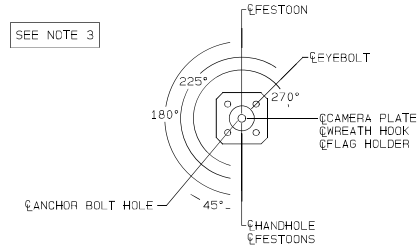

RADIAL INDEX (RFD344285)

ALL ANGLES MEASURED CLOCKWISE FROM HAND-HOLE AS VIEWED FROM SMALL END OF POLE

SEE NOTE 3

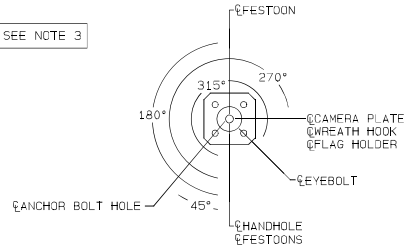

RADIAL INDEX (RFD344286)

ALL ANGLES MEASURED CLOCKWISE FROM HAND-HOLE AS VIEWED FROM SMALL END OF POLE

SEE NOTE 3

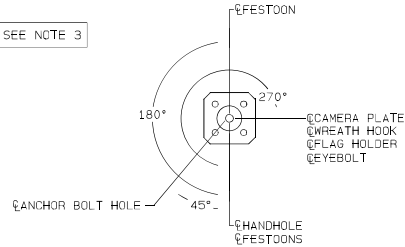

RADIAL INDEX (RFD344287)

NOTES:

- PLEASE PROVIDE CAMERA MOUNTING INFORMATION PRIOR TO RELEASE FOR PRODUCTION.
- PLEASE VERIFY IF NUTSERTS (DETAIL 6) ARE NEEDED, IF NUTSERTS ARE NEEDED PLEASE PROVIDE MOUNTING HEIGHTS AND ORIENTATIONS PRIOR TO RELEASE FOR PRODUCTION.
- PLEASE VERIFY ALL ORIENTATIONS PRIOR TO RELEASE FOR PRODUCTION.
- PLEASE VERIFY ALL MOUNTING HEIGHTS PRIOR TO RELEASE FOR PRODUCTION.

Catalog #'s:

AORTS 26 15.5 3T5 EB (4)FST NUTSERTS CAMERA FPH CHWRPROV CSB BAA RFD344285
 AORTS 26 15.5 3T5 EB (4)FST NUTSERTS CAMERA FPH CHWRPROV CSB BAA RFD344286
 AORTS 26 11 3T5 EB (4)FST NUTSERTS PROV FPH CL27CSB BK BAA RFD344287
 (Pole Details on Sheet 1, Composites on Sheets 3-5)

Customer Signature & Date:



JOB ODESSA STREETScape 2024 ODESSA, MO	ORDER NUMBER: MO696482P3
	PAGE NUMBER: 2 OF 5
TITLE SPAN WIRE STRUCTURES	DRAWING NUMBER TSG015484
	REV C

CUSTOMER NOTES:

1. CUSTOMER SHALL VERIFY DRAWING DETAILS AND PROVIDE PRIOR TO PRODUCTION.
2. CUSTOMER SHALL VERIFY ACCESSORY LOCATION IN TABLE AND PROVIDE PRIOR TO PRODUCTION. MAY BE ROTATED IN VIEW.
3. **ANCHORAGE DETAIL PROVIDED FOR VISUAL ONLY - DO NOT USE TO SET ANCHOR BOLTS.**
4. SIGNED APPROVAL TO ACCOMPANY PO.

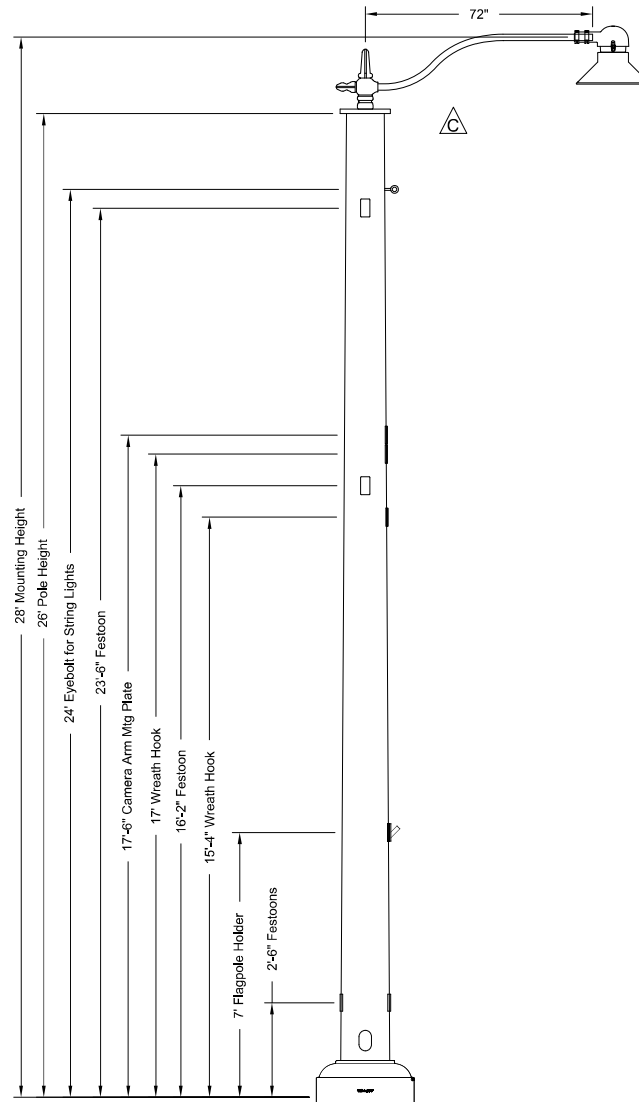

ACCESSORY ORIENTATION DATA		
Description	Height (from AFG)	Orientation
Eyebolt	24'-0"	225°
Festoon	23'-6"	0°
Camera Provision	17'-6"	270°
Wreath Hook	17'-0"	270°
Festoon	16'-2"	0°
Wreath Hook	15'-4"	270°
Flagpole Holder	7'-0"	270°
Festoons	2'-6"	0° & 180°
Handhole	1'-6"	225°

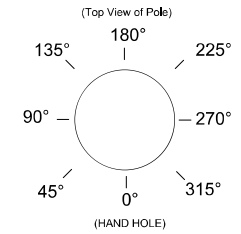

NOTES:

All dimensions are considered to be "on center" unless otherwise noted.

ORIENTATION

Catalog #'s:

Pole: AORTS 26 15.5 3TS EB (4)FST NUTSERTS CAMERA FPH CHWRPROV CSB BAA RFD344285
 Anchor Bolts: VAL2.25 ABSET DOM RFD344285
 Receptacle: FGJUS BK
 Receptacle: FD SS0A 14-50R LKGCVR BK RFD344285
 Roadway Arm: BHC 72IN 1A TN LS BK RFD344285
 Fixture: GSLF3 P20 40K MVOLT ASY ARM BK
 (Pole Details on Sheet 1)

Customer Signature & Date:



An Acuity Brands Company

©2002 ACUITY LIGHTING GROUP INC.,
 214 OAKWOOD AVE., NEWARK, OH 43055

JOB ODESSA STREETScape 2024 ODESSA, MO	ORDER NUMBER: MO696482P3
	PAGE NUMBER: 3 OF 5
TITLE SPAN WIRE STRUCTURES	DRAWING NUMBER TSG015484
	REV C

CUSTOMER NOTES:

1. CUSTOMER SHALL VERIFY DRAWING DETAILS AND PROVIDE PRIOR TO PRODUCTION.
2. CUSTOMER SHALL VERIFY ACCESSORY LOCATION IN TABLE AND PROVIDE PRIOR TO PRODUCTION. MAY BE ROTATED IN VIEW.
3. **ANCHORAGE DETAIL PROVIDED FOR VISUAL ONLY - DO NOT USE TO SET ANCHOR BOLTS.**
4. SIGNED APPROVAL TO ACCOMPANY PO.

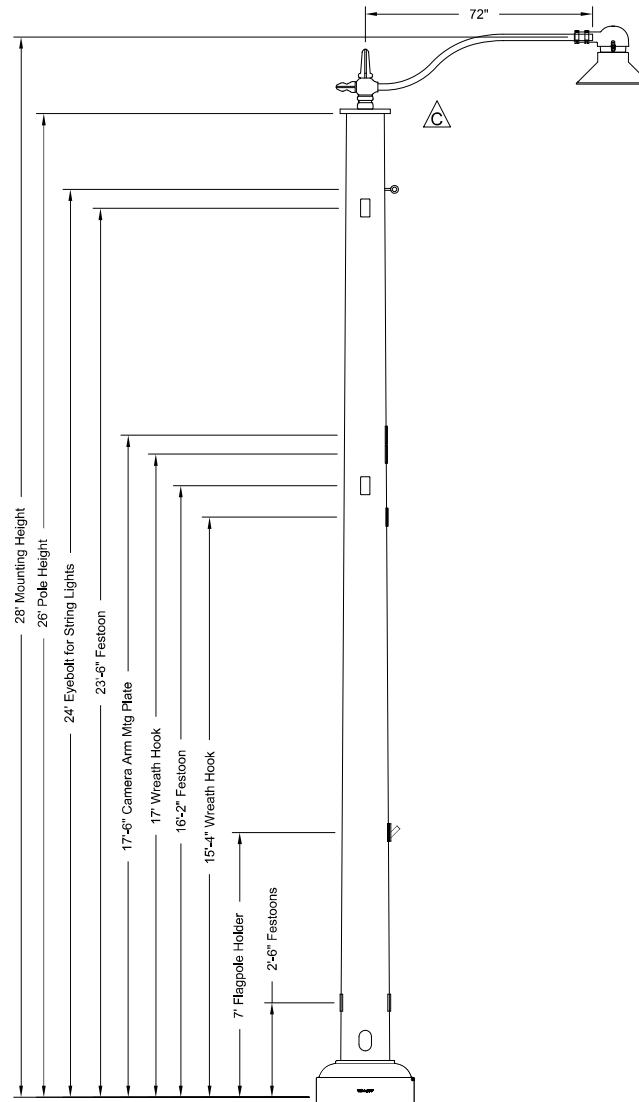

ACCESSORY ORIENTATION DATA		
Description	Height (from AFG)	Orientation
Eyebolt	24'-0"	315°
Festoon	23'-6"	0°
Camera Provision	17'-6"	270°
Wreath Hook	17'-0"	270°
Festoon	16'-2"	0°
Wreath Hook	15'-4"	270°
Flagpole Holder	7'-0"	270°
Festoons	2'-6"	0° & 180°
Handhole	1'-6"	225°

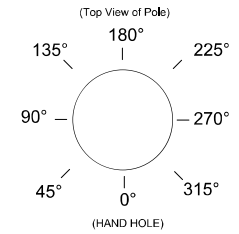

NOTES:

All dimensions are considered to be "on center" unless otherwise noted.

Catalog #'s:

Pole: AORTS 26 15.5 3TS EB (4)FST NUTSERTS CAMERA FPH CHWRPROV CSB BAA RFD344286
 Anchor Bolts: VAL2.25 ABSET DOM RFD344286
 Receptacle: FGJUS BK
 Receptacle: FD SS0A 14-50R LKGCVR BK RFD344286
 Roadway Arm: BHC 72IN 1A TN LS BK RFD344286
 Fixture: GSLF3 P20 40K MVOLT ASY ARM BK
 (Pole Details on Sheet 1)

Customer Signature & Date:



An Acuity Brands Company

©2002 ACUITY LIGHTING GROUP INC.,
 214 OAKWOOD AVE., NEWARK, OH 43055

JOB	ODESSA STREETScape 2024 ODESSA, MO	ORDER NUMBER:	MO696482P3
TITLE	SPAN WIRE STRUCTURES	PAGE NUMBER:	4 OF 5
		DRAWING NUMBER	TSG015484
		REV	C

CUSTOMER NOTES:

1. CUSTOMER SHALL VERIFY DRAWING DETAILS AND PROVIDE PRIOR TO PRODUCTION.
2. CUSTOMER SHALL VERIFY ACCESSORY LOCATION IN TABLE AND PROVIDE PRIOR TO PRODUCTION. MAY BE ROTATED IN VIEW.
3. **ANCHORAGE DETAIL PROVIDED FOR VISUAL ONLY - DO NOT USE TO SET ANCHOR BOLTS.**
4. SIGNED APPROVAL TO ACCOMPANY PO.

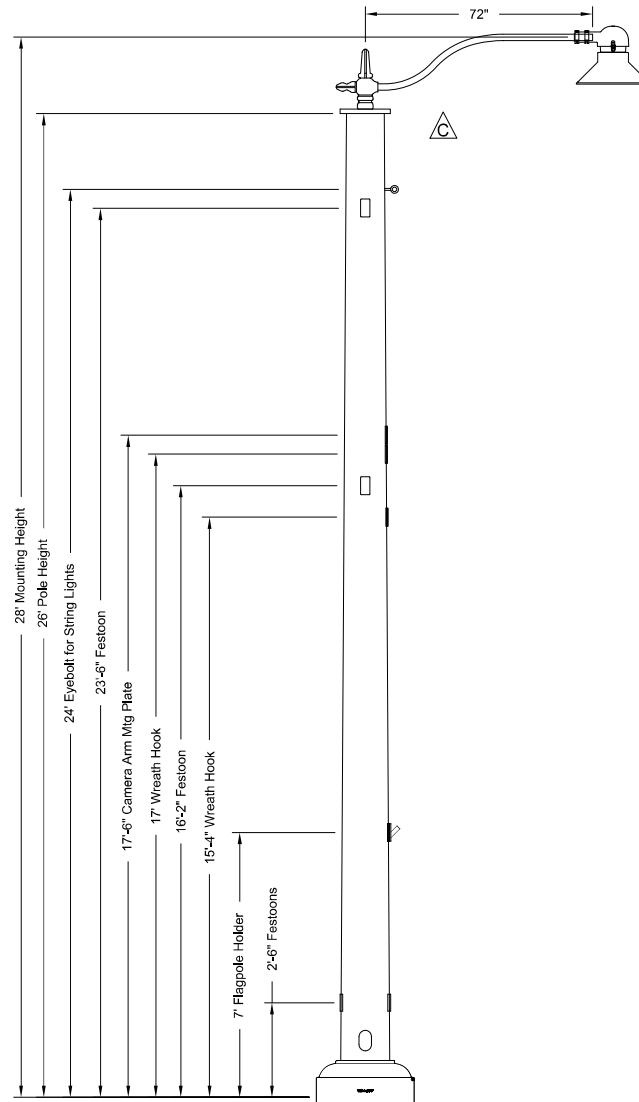

ACCESSORY ORIENTATION DATA		
Description	Height (from AFG)	Orientation
Eyebolt	24'-0"	270°
Festoon	23'-6"	0°
Camera Provision	17'-6"	270°
Wreath Hook	17'-0"	270°
Festoon	16'-2"	0°
Wreath Hook	15'-4"	270°
Flagpole Holder	7'-0"	270°
Festoons	2'-6"	0° & 180°
Handhole	1'-6"	225°

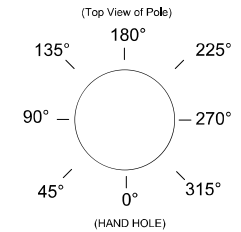

ORIENTATION

NOTES:

All dimensions are considered to be "on center" unless otherwise noted.

Catalog #'s:

Pole: AORTS 26 11 3T5 EB (4)FST NUTSERTS PROV FPH CL27CSB BK BAA **RFD344287**
 Anchor Bolts: VAL1.75 ABSET DOM **RFD344287**
 Receptacle: FGIUS BK
 Receptacle: FD SS0A 14-50R LKGCVR BK **RFD344287**
 Roadway Arm: BHC 72IN 1A TN LS BK **RFD344287**
 Fixture: GSLF3 P20 40K MVOLT ASY ARM BK
 (Pole Details on Sheet 1)

Customer Signature & Date:



An Acuity Brands Company

©2002 ACUITY LIGHTING GROUP INC.,
 214 OAKWOOD AVE., NEWARK, OH 43055

JOB	ODESSA STREETScape 2024 ODESSA, MO
TITLE	SPAN WIRE STRUCTURES

ORDER NUMBER:	MO696482P3
PAGE NUMBER:	5 OF 5
DRAWING NUMBER	TSG015484

REV	5
REV	C



PART VII: BID PAGE

Bid No. 03-24

Light Poles and Bollards (Furnish Only)

Bidder must complete the following section in its entirety, sign and date where indicated.

A. TOTAL PRICE: (Price to be FOB City of Odessa. Prepay and allow the freight to delivery location as specified herein.

Item	Units	Unit Price	Total
Illuminated Bollards			
Light Pole Assembly: RFD344285			
Light Pole Assembly: RFD344286			
Light Pole Assembly: RFD344287			
Total Base Bid:			

B. ACCEPTANCE OF BID BY CITY:

The City shall have _____ calendar days (60 calendar days unless a different period is inserted by bidder) from the date of opening, to accept bidder's offer.

C. DELIVERY DATE ON OR BEFORE _____

D. TERMS / DISCOUNTS: Net _____ DISCOUNTS OFFERED: _____% _____ DAYS
(after receipt of invoice) (for prompt payment)

E. SIGNATURE(S):

Company Name and Address

Signature (Authorized Representative)

Title _____
Telephone _____

DATE _____